

APPLY LUBRICANT TO ALL SEALS  
PRIOR TO INSTALLATION.  
DO NOT USE SILICONE TYPE LUBRICANTS.  
FOR PROPER ARM MOUNTING SEE IS1505.

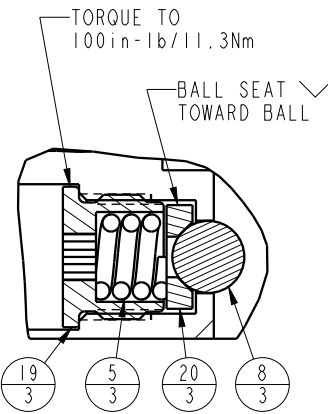

No.	QTY	PART No.	DESCRIPTION	Std. Seal Kit	FKM Seal Kit	Spring Kit
N/A	N/A	IS1505	INSTRUCTION SHEET, ARM INSTALLATION			
N/A	N/A	61704033	SPRING KIT			
N/A	N/A	6V711043	SEAL KIT, FKM			
N/A	N/A	60711043	SEAL KIT, STANDARD			
27	1	39V11051	WIPER, PRESS-IN, (1-1/2)	X	X	
26	1	39H52001	SEAL, U-CUP, 1-3/4 x 3/16 x 2-1/8	X	39V52001	
25	1	39H51002	O-RING, (-033)	X	39V51002	
24	1	81592122	CAM, SC, LP, 7500/33KN, LH, TC			
23	1	81592100	DISK, Ø1.00 X .19			X
22	1	81542102	BASE, SC, BF, LP, 33KN			
21	1	81532111	PLUG, SC, LP, 7500&33KN, SA, TC			
20	3	81532108	SEAT, BALL, SC, LP, TC			
19	3	81532107	RETAINER, SC, LP, TC			
18	1	81512110	PLUNGER, SC, LP, 7500&33KN, SA, TC			
17	1	49001905	BREATHER, 1/4 BSPP			
16	1	43068006	PLUG, 1/4 BSPP MALE			
15	1	39054018	BU RING, (-327)	X	X	
14	1	39054017	BU RING, (-033)	X	39054023	
13	1	39054016	BU RING, (1.5x.125x.063)	X	X	
12	2	39051041	O-RING, (-006)	X	39V51041	
11	2	39050042	O-RING, (-011)	X	39051025	
10	1	39011075	SEAL, LL, (1-1/2 X 1/8 X 1/8 1-3/4)	X	39V11075	
9	1	39001056	O-RING, (-119)	X	X	X
8	3	23650004	BALL, TUNGSTEN-CARBIDE .250			
7	1	23600011	BALL, STEEL, ALLOY, .187			X
6	1	23350068	SPRING, COMPRESSION			X
5	3	23350066	SPRING, COMPRESSION			
4	10	21500305	SHCS, M8 X 1.25-6G X 30MM			
3	2	21500200	WASHER			
2	3	21500031	SHCS, M5 X 0.8 X 14, ALY			
1	2	21500019	SCREW, CAP, BTNH, M3 X 6, ALY			

### PARTS LIST



VEKTEK, INC.  
1334 E. SIXTH AVE. P.O. BOX 625  
EMPORIA, KS. 66801 U.S.A.

ASSEMBLIES AFFECTED  
41423312  
41423312F

SIZE A  
MPL7172  
REV C

C	5762	RELEASE	JDW	07/18/25
REV	IN ACCORDANCE WITH ECN	EFFECTIVE DATE	REVISED BY	DATE
DRW BY:	JDW	DRAWING STATUS: <b>Released</b>		
DATE:	6-17-11	PRODUCTION APPROVED FOR RELEASED STATUS ONLY		

